

Alcoa
Fastening
Systems



INSTRUCTION MANUAL

ALL MODEL 585 SERIES

HYDRAULIC INSTALLATION TOOLS



Makers of Huck®, Marson®, Recoil®
Brand Fasteners, Tools & Accessories

July 29, 2014
HK602







CONTENTS

Safety	4
Description	5
Specifications	5
Principle of Operation	6
585 Component Identification	7
585 Clearance Dimensions	7
Preparation for Use	8
Operating Instructions	8
Maintenance	9
Disassembly and Assembly Preparation	10
Disassembly	11
Assembly	12
Assembly Drawings with Part Numbers	13-17
Troubleshooting	18
Kits and Accessories	18
Product Updates	19-20



SAFETY INSTRUCTIONS

GLOSSARY OF TERMS AND SYMBOLS:



- Product complies with requirements set forth by the relevant European directives.



- **READ MANUAL** prior to using this equipment.



- **EYE PROTECTION IS REQUIRED** while using this equipment.



- **HEARING PROTECTION IS REQUIRED** while using this equipment.



WARNINGS: Must be understood to avoid severe personal injury.



CAUTIONS: show conditions that will damage equipment and or structure.

Notes: are reminders of required procedures.

Bold, Italic type and underlining: emphasizes a specific instruction.

I. GENERAL SAFETY RULES:

1. A half hour long hands-on training session with qualified personnel is recommended before using Huck equipment.
2. Huck equipment must be maintained in a safe working condition at all times. Tools and hoses should be inspected at the beginning of each shift/day for damage or wear. Any repair should be done by a qualified repairman trained on Huck procedures.
3. For multiple hazards, read and understand the safety instructions before installing, operating, repairing, maintaining, changing accessories on, or working near the assembly power tool. Failure to do so can result in serious bodily injury.
4. Only qualified and trained operators should install, adjust or use the assembly power tool.
5. Do not modify this assembly power tool. This can reduce effectiveness of safety measures and increase operator risk.
6. Do not discard safety instructions; give them to the operator.
7. Do not use assembly power tool if it has been damaged.
8. Tools shall be inspected periodically to verify all ratings and markings required, and listed in the manual, are legibly marked on the tool. The employer/operator shall contact the manufacturer to obtain replacement marking labels when necessary. Refer to assembly drawing and parts list for replacement.
9. Tool is only to be used as stated in this manual. Any other use is prohibited.
10. Read MSDS Specifications before servicing the tool. MSDS specifications are available from the product manufacturer or your Huck representative.
11. Only genuine Huck parts shall be used for replacements or spares. Use of any other parts can result in tooling damage or personal injury.
12. Never remove any safety guards or pintail deflectors.
13. Never install a fastener in free air. Personal injury from fastener ejecting may occur.
14. Where applicable, always clear spent pintail out of nose assembly before installing the next fastener.
15. Check clearance between trigger and work piece to ensure there is no pinch point when tool is activated. Remote triggers are available for hydraulic tooling if pinch point is unavoidable.
16. Do not abuse tool by dropping or using it as a hammer. Never use hydraulic or air lines as a handle or to bend or pry the tool. Reasonable care of installation tools by operators is an important factor in maintaining tool efficiency, eliminating downtime, and preventing an accident which may cause severe personal injury.
17. Never place hands between nose assembly and work piece. Keep hands clear from front of tool.
18. Tools with ejector rods should never be cycled with out nose assembly installed.
19. When two piece lock bolts are being used always make sure the collar orientation is correct. See fastener data sheet for correct positioning.

II. PROJECTILE HAZARDS:

1. Risk of whipping compressed air hose if tool is pneudraulic or pneumatic.
2. Disconnect the assembly power tool from energy source when changing inserted tools or accessories.
3. Be aware that failure of the workpiece, accessories, or the inserted tool itself can generate high velocity projectiles.
4. Always wear impact resistant eye protection during tool operation. The grade of protection required should be assessed for each use.
5. The risk of others should also be assessed at this time.
6. Ensure that the workpiece is securely fixed.
7. Check that the means of protection from ejection of fastener or pintail is in place and operative.
8. There is possibility of forcible ejection of pintails or spent mandrels from front of tool.

III. OPERATING HAZARDS:

1. Use of tool can expose the operator's hands to hazards including: crushing, impacts, cuts, abrasions and heat. Wear suitable gloves to protect hands.
2. Operators and maintenance personnel shall be physically able to handle the bulk, weight and power of the tool.
3. Hold the tool correctly and be ready to counteract normal or sudden movements with both hands available.
4. Maintain a balanced body position and secure footing.
5. Release trigger or stop start device in case of interruption of energy supply.
6. Use only fluids and lubricants recommended by the manufacturer.
7. Avoid unsuitable postures, as it is likely for these not to allow counteracting of normal or unexpected tool movement.
8. If the assembly power tool is fixed to a suspension device, make sure that fixation is secure.
9. Beware of the risk of crushing or pinching if nose equipment is not fitted.

IV. REPETITIVE MOTION HAZARDS:

1. When using assembly power tool, the operator can experience discomfort in the hands, arms, shoulders, neck or other parts of the body.
2. When using tool, the operator should adopt a comfortable posture while maintaining a secure footing and avoid awkward or off balanced postures.
3. The operator should change posture during extended tasks to help avoid discomfort and fatigue.
4. If the operator experiences symptoms such as persistent or recurring discomfort, pain, throbbing, aching, tingling, numbness, burning sensations or stiffness, these warnings should not be ignored. The operator should tell the employer and consult a qualified health professional.

V. ACCESSORIES HAZARDS:

1. Disconnect tool from energy supply before changing inserted tool or accessory.
2. Use only sizes and types of accessories and consumables that are recommended. Do not use other types or sizes of accessories or consumables.

VI. WORKPLACE HAZARDS:

1. Be aware of slippery surfaces caused by use of the tool and of trip hazards caused by the air line or hydraulic hose.
2. Proceed with caution while in unfamiliar surroundings; there could be hidden hazards such as electricity or other utility lines.
3. The assembly power tool is not intended for use in potentially explosive environments.
4. Tool is not insulated against contact with electrical power.
5. Ensure there are no electrical cables, gas pipes, etc., which can cause a hazard if damaged by use of the tool.

VII. NOISE HAZARDS:

1. Exposure to high noise levels can cause permanent, disabling hearing loss and other problems such as tinnitus, therefore risk assessment and the implementation of proper controls is essential.
2. Appropriate controls to reduce the risk may include actions such as damping materials to prevent workpiece from 'ringing'.
3. Use hearing protection in accordance with employer's instructions and as required by occupational health and safety regulations.
4. Operate and maintain tool as recommended in the instruction handbook to prevent an unnecessary increase in the noise level.
5. Select, maintain and replace the consumable / inserted tool as recommended to prevent an unnecessary increase in noise.
6. If the power tool has a silencer, always ensure that it is in place and in good working order when the tool is being operated.

VIII. VIBRATION HAZARDS:

1. Exposure to vibration can cause disabling damage to the nerves and blood supply to the hands and arms.
2. Wear warm clothing when working in cold conditions and keep hands warm and dry.
3. If numbness, tingling, pain or whitening of the skin in the fingers or hands, stop using the tool, tell your employer and consult a physician.
4. Support the weight of the tool in a stand, tensioner or balancer in order to have a lighter grip on the tool.

X. HYDRAULIC TOOL SAFETY INSTRUCTIONS:

1. Do not exceed maximum pressure setting stated on tool.
2. Carry out a daily check for damaged or worn hoses or hydraulic connections and replace if necessary.
3. Use only clean oil and filling equipment.
4. Power units require a free flow of air for cooling purposes and should therefore be positioned in a well ventilated area free from hazardous fumes.
5. Ensure that couplings are clean and correctly engaged before operation.
6. Do not inspect or clean the tool while the hydraulic power source is connected. Accidental engagement of the tool can cause serious injury.
7. Be sure all hose connections are tight.
8. Wipe all couplers clean before connecting. Failure to do so can result in damage to the quick couplers and cause overheating.



DESCRIPTION

GENERAL

Huck Model 585 Hydraulic Installation Tool (H.I.T.) is designed to install a variety of HUCKBOLT® fasteners and Huck Blind Fasteners. The tool is designed to operate on 5400-5700 psi (37250-39300 kPa) PULL and 2200-2400 psi (15200-16500 kPa) RETURN pressures as supplied by Huck hydraulic Powerig® Models 906, 908, 910, 911, 914, 917 and 940, or equivalent.

The Model 585 must be equipped with a Nose Assembly designed for the installation of a specific fastener. Each tool is basically a cylinder and piston assembly. An unloading valve, designed to relieve the hydraulic pressure at both ends of the stroke, is posi-

tioned by the piston. A pintail ejector is provided to eject the broken pintail from the nose assembly. The end of the piston rod is threaded, and a nose adapter, split ring and sleeve are included for attaching nose assemblies to tool.

Except for nose assembly, each tool is complete with handle, hoses, couplers and control cord ready to be attached to the Powerig hoses and control cord.

Figure 1 is a sectional view, Figure 2 is clearance dimensional view, and Figure 3 is an exploded view of the 585 H.I.T.

SPECIFICATIONS

Length (overall)	6.98 in.	177mm
Width (maximum)	4.25 in.....	108 mm
Height (including handle)	10.85 in.....	276 mm
Weight	19 lbs	8.6 kg
Stroke	1.60 in.....	41 mm
Fasteners Installed	See SELECTION CHART, Form 461	
Power Source.....	Huck Hydraulic POWERIGS®	
PULL Pressure	5400-570 psi	37250-39300 kPa
RETURN Pressure	2200-2400 psi	15200-16500 kPa

(1) Lengths and weights do not include nose assemblies.



PRINCIPLE OF OPERATION

See Figure 1

When tool hoses and control cord are connected to Powerig hoses and control cord, PULL and RETURN strokes of tool are controlled by a switch in the handle. When the switch is depressed, a solenoid operated valve in the Powerig directs pressured hydraulic fluid through the PULL hose to the front side of piston, and allows fluid on the RETURN side to flow back to tank. The piston and nose assembly collet moves rearward causing follower O-rings and/or spring to impart a forward motion to the follower. If tool and nose assembly is in position on a fastener pin and

collar, this forward motion causes the jaws to clamp onto pintail of fastener and installation cycle commences. Clamping pressure is applied to the sheets. The anvil is forced forward, swaging the collar into locking grooves of the fastener. When the anvil hits the sheet, continued pull causes the pintail to break off.

When the piston reaches the end of its PULL stroke, it uncovers flats on the rear end of the unloading valve. These flats were designed to provide a passage for hydraulic fluid from PULL side to RETURN side of piston, "unloading" or "dumping" the pressurized fluid back to tank. When the switch is released, the solenoid is de-energized and the valve directs pressurized fluid to rear side of the piston and allows fluid on PULL side to flow back to tank. This causes piston and collet to move forward and pushes nose assembly and tool off the swaged (installed) fastener.

Nose assembly jaw release contacts jaws, causing them to open and release the broken-off pintail. The ejector rod hydraulically ejects the pintail out the front of the nose assembly. When the piston reaches the end of its RETURN stroke, pressure is built up causing the POWERIG idler valve (except on Models 910, 911 and 940 to go to idling pressure). Idling pressure keeps the tool piston and nose assembly collet, jaws, etc. in the forward position ready for the next installation cycle.

A flat on the front end of the unloading valve was designed to provide a passage for hydraulic fluid from RETURN side of piston to PULL side of piston and back to tank.

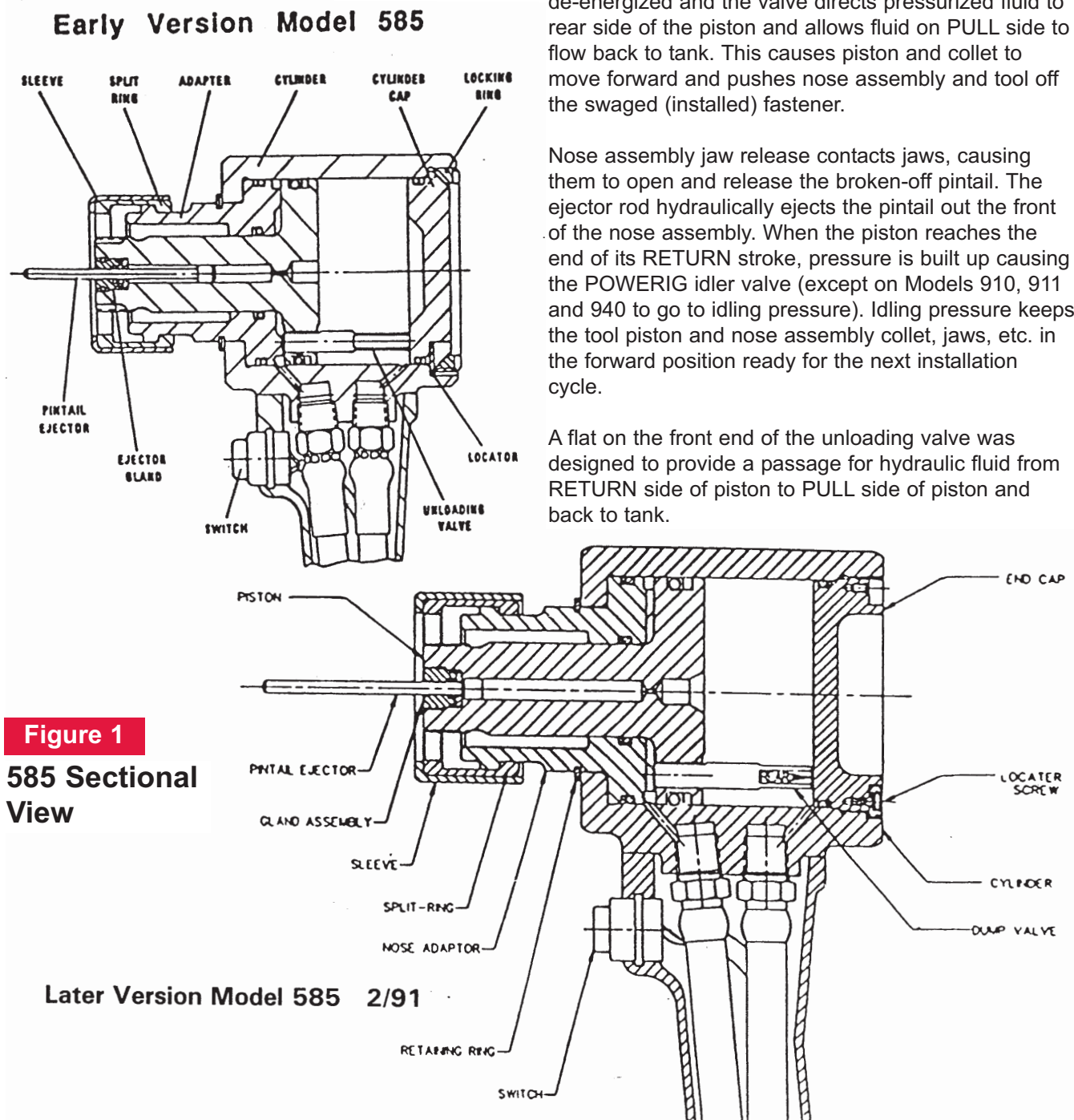

Figure 1
585 Sectional View

Later Version Model 585 2/91

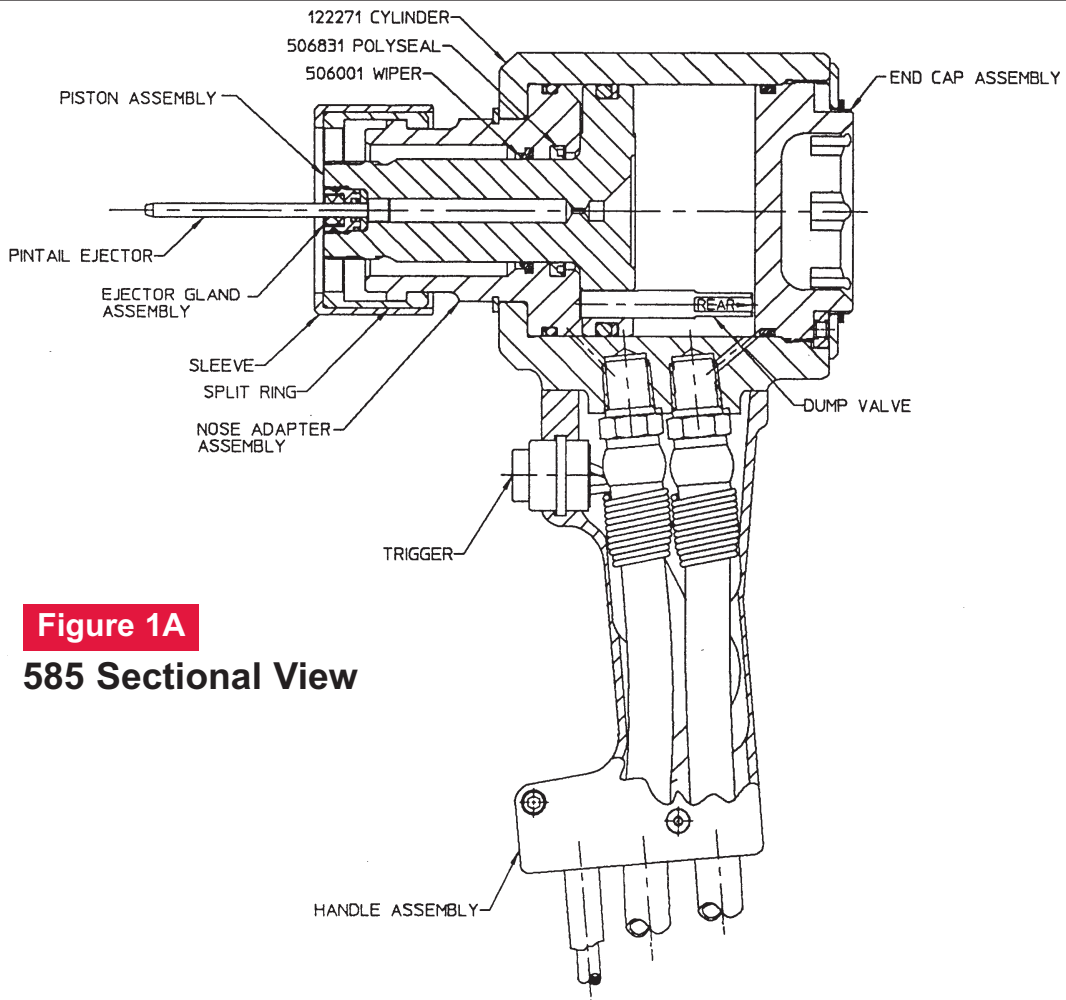

Figure 1A
585 Sectional View

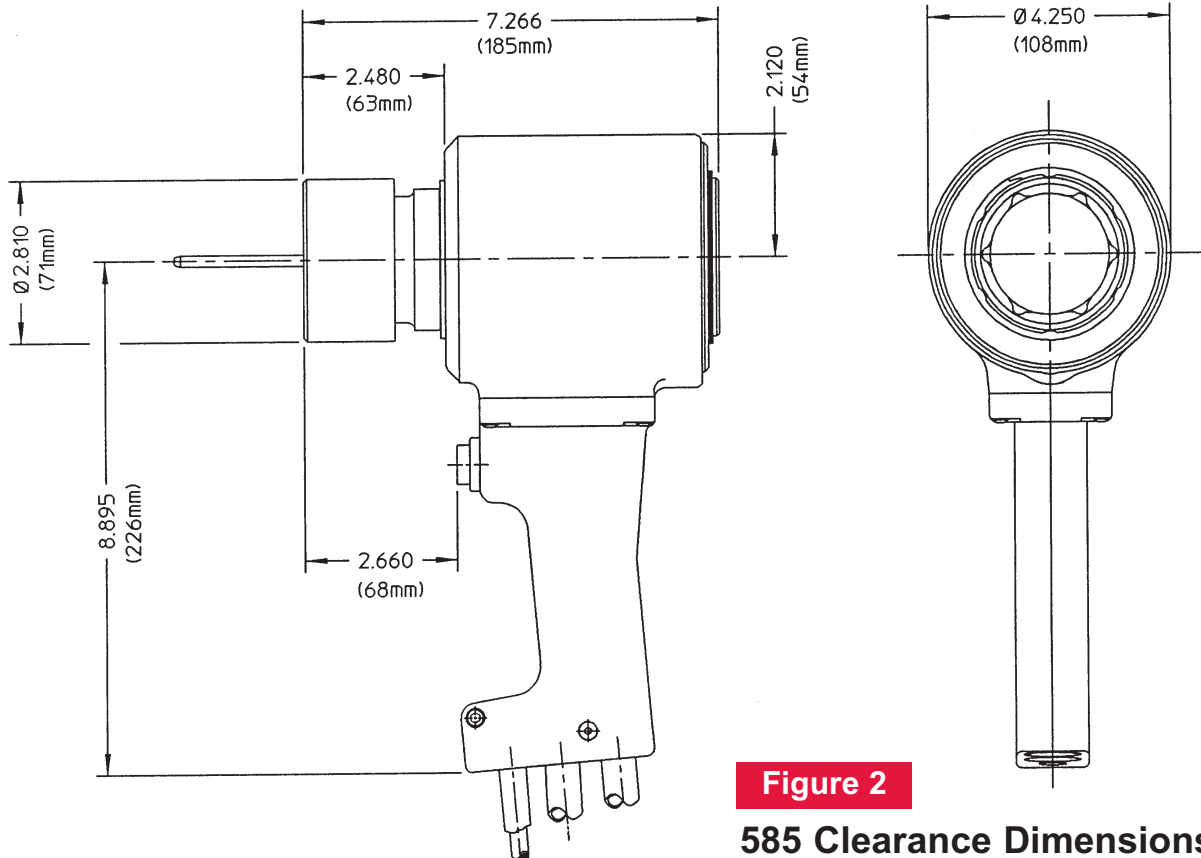

Figure 2
585 Clearance Dimensions



PREPARATION FOR USE

CAUTION: KEEP DIRT AND OTHER FOREIGN MATTER OUT OF THE HYDRAULIC SYSTEMS OF THE TOOLS, HOSES, COUPLERS AND POWERIG. DO NOT LET HOSE FITTINGS AND COUPLERS CONTACT A DIRTY FLOOR OR UNCLEAN WORK SURFACE. FOREIGN MATTER IN HYDRAULIC FLUID WILL CAUSE THE TOOL AND POWERIG VALVES TO MALFUNCTION.

Power Source Connections

Coat pipe plug threads, hose fitting threads, and quick connect fittings with Threadmate™, which is available from Huck in a 4oz. tube as part number 508517.

Threadmate is a registered trademark of Parker Intangibles LLC

CAUTION: Do not use TEFLON® tape on pipe threads. Pipe threads may cause tape to shred resulting in tool malfunction. TEFLON is a registered trademark of E.I. du Pont de Nemours and Company

1. Screw PULL pressure hose, with coupler nipple into port “P”. Screw RETURN pressure hose, with

coupler body, into port “R”.

2. Use a Huck POWERIG, or equivalent, that has been prepared for operation per applicable Instruction Manual. Check both PULL and RETURN pressures, and adjust as necessary.
3. Turn POWERIG to “OFF” and couple tool hoses to POWERIG hoses. Be sure that the hoses run from tool port “P” to Powerig port “PULL PRESSURE” and from tool port “R” to Powerig port “RETURN PRESSURE.”
4. Connect switch cord to POWERIG cord.
5. Turn POWERIG to “ON”. Depress and release switch a few times to circulate hydraulic fluid. Observe action of tool. Check for fluid leaks.
6. Attach the proper Nose Assembly to the tool.

OPERATING INSTRUCTIONS



WARNING: HUCK RECOMMENDS THAT ONLY HUCK HYDRAULIC POWERIGS BE USED AS THE POWER SOURCE FOR HUCK INSTALLATION EQUIPMENT. HYDRAULIC POWER UNITS THAT DELIVER HIGH PRESSURE FOR BOTH “PULL” AND “RETURN” AND ARE NOT EQUIPPED WITH RELIEF VALVES ARE SPECIFICALLY NOT RECOMMENDED AND MAY BE DANGEROUS.



WARNING: REASONABLE CARE OF INSTALLATION TOOLS BY OPERATORS IS AN IMPORTANT FACTOR IN MAINTAINING TOOL EFFICIENCY AND IN REDUCING REPAIR DOWNTIME. DO NOT ABUSE THE TOOL BY DROPPING IT, USING IT AS A HAMMER OR OTHERWISE. CAUSING UNNECESSARY WEAR AND TEAR. BE SURE THERE IS ADEQUATE CLEARANCE FOR THE TOOL AND OPERATOR’S HANDS BEFORE PROCEEDING. DO NOT CONNECT TOOL HOSES TO EACH OTHER AND USE AS A HANDLE FOR CARRYING.

3. Slide HUCKBOLT collar over pin. (The beveled end of the collar must be towards the nose assembly and tool.)
4. Push nose assembly onto the pin until the nose assembly anvil stops against the collar. Tool and nose assembly must be held at right angles (90O) to the work.
5. Depress tool switch to start installation cycle.
6. When forward motion of nose assembly anvil stops and pintail breaks off, release switch. Tool will go into its return stroke, push off the installed fastener and eject the pintail.
7. The tool and nose assembly is ready for the next installation cycle.



WARNING: DO NOT PULL ON PIN WITHOUT A COLLAR. IF A PIN IS PULLED WITHOUT COLLAR, THE PIN WILL EJECT FORCIBLY WHEN THE PINTAIL BREAKS OFF.

To install a HUCKBOLT Fastener:

1. Check work and remove excessive gap. (Gap is the space between sheets. Gap is excessive if not enough pintail sticks through the collar for the nose assembly jaws to grab onto).
2. Put HUCKBOLT pin into hole.



MAINTENANCE

PREVENTIVE MAINTENANCE

NOTE: Refer to the applicable section for assembly or disassembly. For supplementary information refer to Troubleshooting Chart and Parts List.

System Inspection

Operating efficiency of the installation tool is directly related to performance of the complete system, including the tool with nose assembly, hydraulic hoses, switch and control cord, and Powerig. Therefore, an effective preventive maintenance program includes scheduled inspections of the system to detect and correct minor troubles.

1. Inspect tool and nose for external damage.
2. Verify that hydraulic hose fittings and couplings and electrical connections are secure.
3. Inspect hydraulic hoses for signs of damage or aging. Do not carry tool suspended from hoses coupled together. Replace hoses if damaged.
4. Inspect tool, hose, and POWERIG during operation to detect abnormal heating, leaks, or vibration.

Powerig Maintenance

Maintenance instructions and repair procedures are in the applicable Powerig instruction manual.

Tool Maintenance

At regular intervals, depending upon use, replace all O-rings and back-up rings in the tool. Spare Parts Kits should be kept on hand. Inspect cylinder bore, piston and piston rod, and unloading valve for scored surfaces, excessive wear or damage, and replace as necessary.

Nose Assembly Maintenance

Frequent cleaning of the nose assembly is recommended. Dip nose assembly in mineral spirits, or other suitable solvent, to clean jaws and wash away metal chips and dirt. If more thorough cleaning or maintenance is necessary, disassemble the nose assembly. Use a sharp pointed "pick" to remove imbedded particles from the pull grooves of the jaws. Reassemble Nose Assembly.



DISASSEMBLY AND ASSEMBLY PREPARATION

GENERAL

During disassembly and assembly, take the following precautions to avoid damaging tool or components:

- (a) Always work on a clean surface.
- (b) Use relatively soft materials, such as brass, aluminum or wood, to protect tool when applying pressure.
- (c) Apply a continuous strong pressure, rather than sharp blows, to disassemble or assemble a component. An arbor press provides steady pressure to press a component in or out.
- (d) Never continue to force a component if it "hangs up" due to misalignment. Reverse the procedure to correct misalignment and start over.
- (e) Smear LUBRIPLATE™ 130-AA, or equivalent, on O-rings and mating surfaces to aid assembly and prevent damage to O-rings. A handy tube of Lubriplate 130-AA is available from Huck as part number 502723.
- (f) Coat pipe plug threads, hose fitting threads, and quick connect fittings with Threadmate™, which is available from Huck in a 4oz. tube as part number 508517.

CAUTION: Do not use TEFLON® tape on pipe threads. Pipe threads may cause tape to shred resulting in tool malfunction. (Threadmate™ is available from Huck in a 4oz. tube as part number 508517.)

DISASSEMBLY AND ASSEMBLY TOOLS

Standard hand tools such as wrenches, drifts, copper or lead hammers, screwdrivers, socket screw hexagon keys, long forceps (tweezers), etc. which can be purchased at most local supply firms are required. If possible, an arbor press and vise with soft jaws should be available. Standard tools available from Huck are shown in Table 3. Wrench, 122048, is available for Ejector Gland. Wrench, 124434, is available for End Cap.

SPARE PARTS AND SPARE PARTS KITS

The quantity of spare parts that should be kept on hand varies with the application and number of tools in service. However, spare parts kits containing perishable parts such as O-rings, back-up rings, etc., should be kept on hand at all times. Parts included in Spare Parts Kit 585KIT are indicated by asterisks (*) Table 4 — PARTS LIST.

- * Threadmate is a registered trademark of Parker Intangibles LLC
- * TEFLON is a registered trademark of DuPont Corp.
- * LUBRIPLATE is a registered trademark of Fiske Brothers Refining Co.

Table 3 - STANDARD TOOLS AVAILABLE FROM HUCK AND THEIR USE

Part No.	Description	Used on	
		Fig. and Ref. No.	Part No.
502294	Hex key, 1/8 across flats	3-11	504128
502295	Hex key, 5/32 across flats	3-21 3-32	501218 502489



DISASSEMBLY

For component identification, refer to Figure 3, EXPLODED VIEW and Table 4, PARTS LIST. Numbers in parenthesis () are reference numbers shown in Figure 3.

The following procedure is for complete disassembly. Disassemble only components necessary to check damaged O-ring, C-ring, back-up ring, or other components.



WARNING: Be sure POWERIG is turned OFF before removing tool or nose assembly for cleaning, or for replacing worn or damaged components.

DISASSEMBLY

1. Uncouple tool hydraulic hoses, and disconnect electrical control cord.
2. Remove Retaining Sleeve (1) and Split Ring Set (2). Remove nose assembly.
3. Remove Coupler Nipple (37) and Coupler Body (38). Drain Hydraulic Hoses (36) into a clean container.
4. Push rearward on Piston (23) until hydraulic fluid is drained into container.
5. Remove Retaining Ring and Cover Plate.
6. Use Wrench, 124434, and remove End Cap.
7. Push rearward on Adapter Assembly (5) and piston, along with adapter, will slide from cylinder.
8. Pull piston out of adapter, and remove Unloading Valve (22) from piston.
9. Remove Ejector Gland Assembly (12 thru 18) and Pintail Ejector (19) from piston. Use Special Wrench, P/N 122048, to unscrew gland.
10. Use a small diameter, dull-pointed rod to remove O-rings, C-ring and back-up rings from all components.
11. Remove Socket Head Cap Screw (21) from Handle Assembly (20).
12. Remove two Button Head Cap Screws (11) from one-half of handle and cylinder.
13. Separate handle halves, and lift out assemble Switch (10), Control Cord Assembly (34) including Connector Assembly (35), and Strain Relief Grommet (33).
14. Remove remaining button head cap screws and handle half. Remove both Hydraulic Hoses (36) from cylinder.
15. Loosen two screws at rear of switch to remove switch from electrical cord. Remove two #6-32 socket set screws to disassemble switch for cleaning. Pull strain relief grommet from cord.
16. Disassemble electrical connector to replace Connector, or to rewire.

NOTE

The ejector gland can be removed to inspect and/or replace components without completely disassembling tool.

9. Remove Ejector Gland Assembly (12 thru 18) and Pintail Ejector (19) from piston. Use Special Wrench, P/N 122048, to unscrew gland.



ASSEMBLY

Before assembling tool:

Clean components in mineral spirits, or other solvent compatible with O-ring seals. Clean out O-ring grooves. Inspect components for scoring, excessive wear or damage. Replace O-rings, C-ring, and back-up rings. Be sure that relative positions of the O-rings, C-ring and back-up rings are as shown in Figures 1, 3, 4 and 5. Specifications for O-rings, back-up rings, and other standard components are given in Table 4, and NOTES, so that they may be purchased locally. Smear Lubriplate 130AA on O-rings, C-ring and mating surfaces to prevent damage to O-rings and C-ring and to aid assembly.

1. Assemble electrical control cord (34) to plug of electrical connector (35).
2. Push cord thru strain relief grommet (33), and attach to switch (10).
3. Screw both hoses (36) into cylinder (4).
4. Loosely attach handle half by turning two button head cap screws (11) into cylinder.
5. Place assembled switch, electrical cord, strain relief grommet and electrical connector into handle recesses. Loosely attach other handle half. Partially turn socket head screw (21) into handle halves. Evenly tighten five cap screws to 50 in. lbs. torque if plated, and 70 in. lbs. if unplated, while holding assembled components in position.
6. Assemble ejector gland assembly and pintail ejector to the piston as follows:
 - a. Insert pintail ejector (19) into piston (23).
 - b. Drop in ejector washer (18).
 - c. Drop in O-ring (15).
 - d. Screw in gland (12) with O-ring (13) in groove in threads, back-up ring (16) and C-ring (17) in I.D., and back-up ring (14) on O.D.
 - e. Tighten ejector gland (12) with wrench, P/N 122048.
7. Push adapter assembly (5) including O-ring and back-up ring into cylinder.
8. Install retaining ring (3) into groove in adapter.
9. Push assembled piston (23) O-rings and back-up ring into assembled cylinder and adapter.
10. Slide unloading valve (22) into hole through piston. **BE SURE UNLOADING VALVE IS ASSEMBLED WITH FOUR FLATS TO THE REAR AS SHOWN.**
11. Tighten end cap, then, back off until locator can be placed in closest matching grooves. Use wrench 124434.
12. After end cap is locked in place, install cover plate and retaining ring.
13. Screw coupler nipple (37) onto hose in port P and coupler body (38) onto hose in port R.
14. Connect tool hoses to Powerig hoses and cycle tool a few times. Observe action of tool and check for leaks.
15. Attach nose assembly to tool. Use split ring set (2) and retaining sleeve (1) furnished with tool.

NOTES

1. All part numbers shown are available from Huck for replacements.
2. Asterisks (*) indicate parts in Spare Parts Kit, Part Number 585KIT.



585

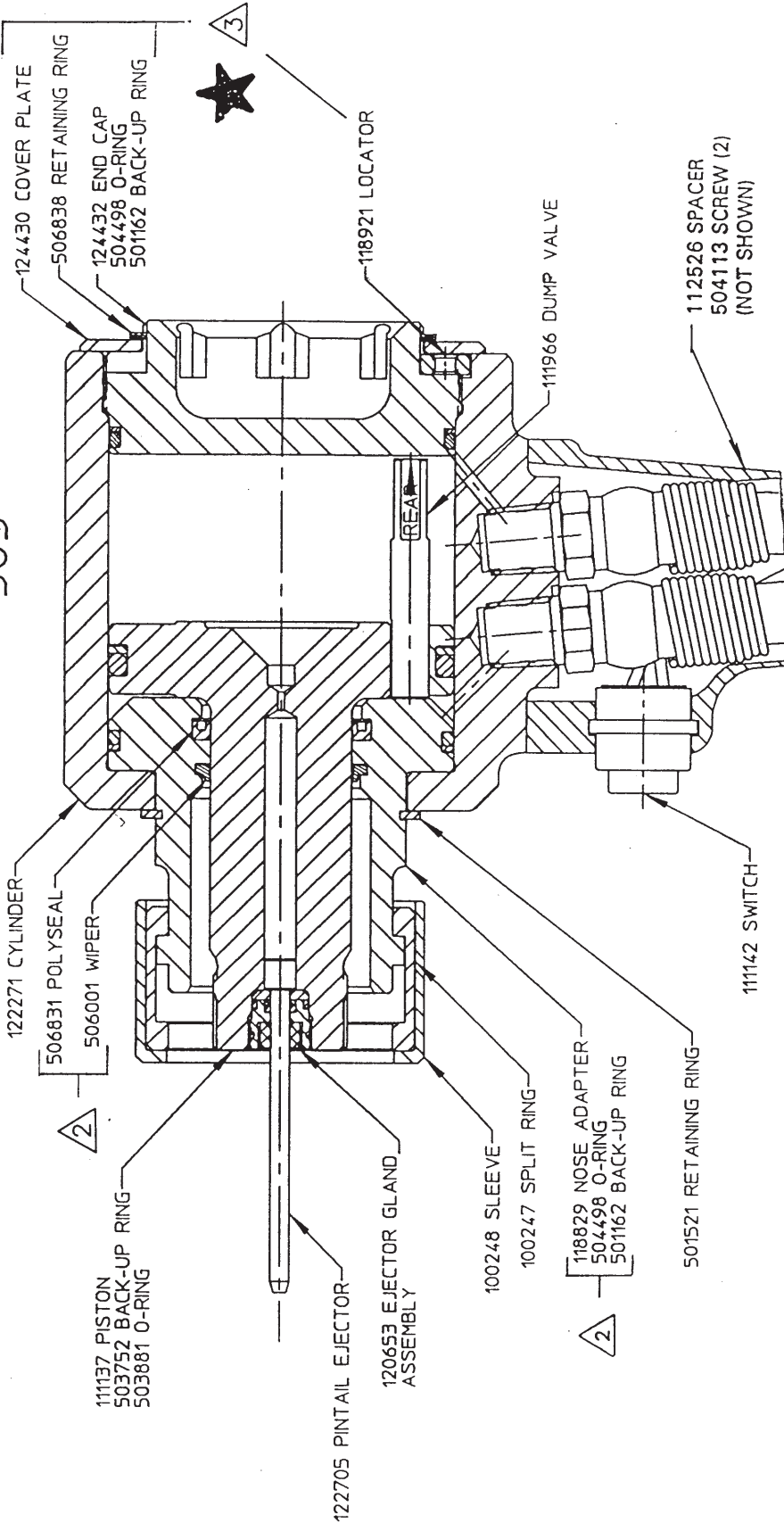

NOTES:

- △ USE TEFLON STICK SEALANT OR EQUIVALENT ON PIPE THREADS.
- 2 SERVICE KIT P/N 585KIT AVAILABLE FOR SERVICE PARTS.
- 3 SHIP WITH EJECTOR GLAND HEX KEY P/N 122048 AND END CAP HEX KEY 124434.

PLEASE NOTE:

Assembly includes latest single component part numbers.
 To obtain entire sub-assembly when purchasing a main component, please include related parts, for example, piston; O-ring; back-up ring.

Fig. 3



Fig. 3a

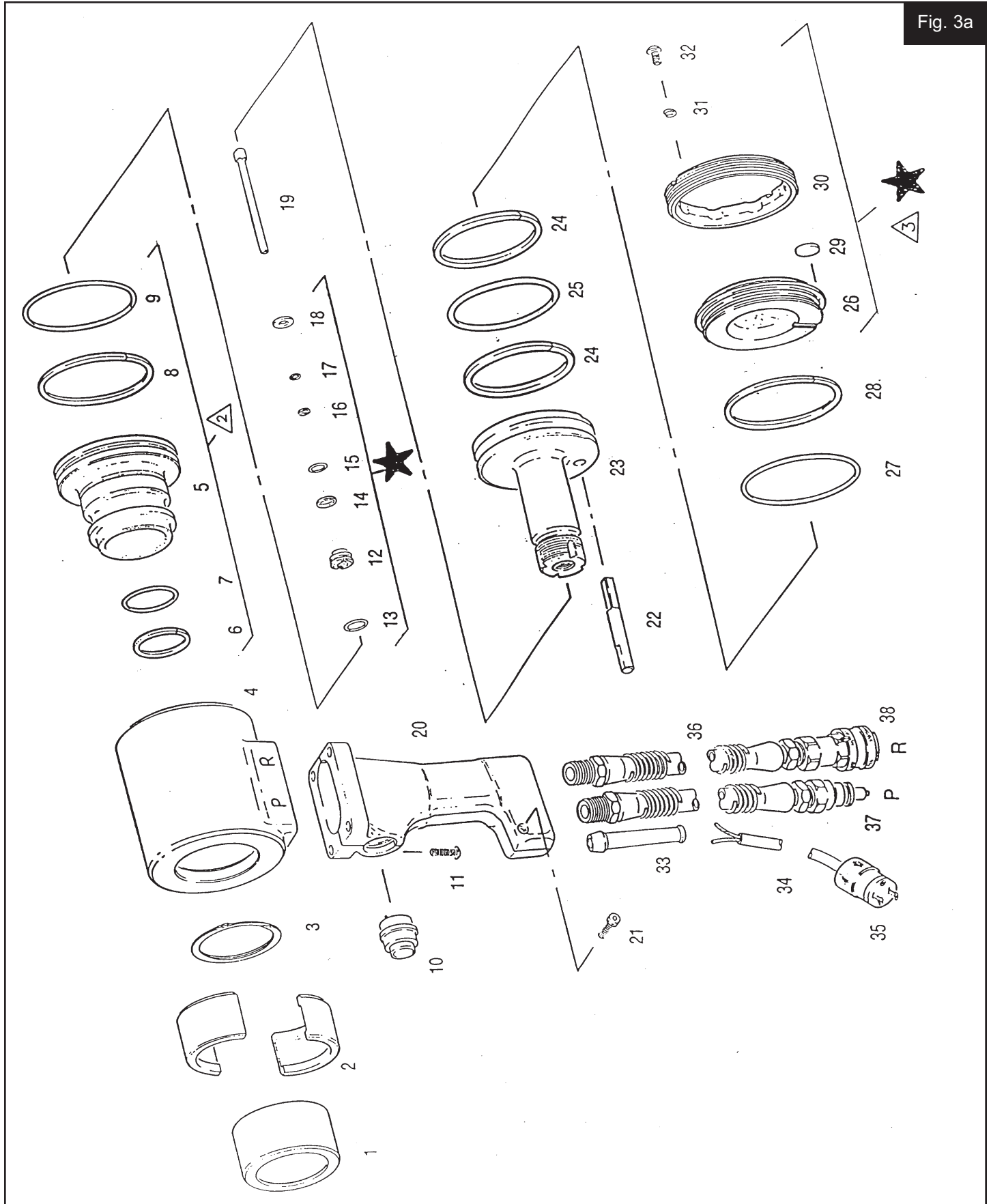

Exploded View



NOTE



Except where notes show otherwise, illustration and parts list (Fig. 3 & 3a) apply to latest 585. Illustration and P/L without , , and star (Fig. 3 & 3a) are for tools prior to 4-19-95.

Table 4 - PARTS LIST

REF. NO.	PART NO.	NO. REQ.	DESCRIPTION
--	104644	1	Split Ring Group (includes 1 & 2)
1	100248	1	Retaining Sleeve
2	100247	1	Split Ring Set
3*	501521	1	Retaining Ring—Spirolox RST 243
4	111291	1	Cylinder
5	111289	1	Adapter (includes 6, 7, 8 & 9)
6*	501147	1	Back-up Ring—S-11248-220
7*	504626	1	O-ring—AS 568-220
8*	501162	1	Back-up Ring—S-11248-235
9*	504498	1	O-ring—AS 568-235
10	111142	1	Switch
11*	504128	4	Screw-But. Hd. Cap—#10-32 X 3/4
--	111292	1	Piston Assembly (includes 12 thru 25)
12	104638	1	Ejector Gland Assem. (Incl. 13 thru 18)
13*	504408	1	O-ring AS 568-012
14*	501085	1	Back-up Ring—S-11248-13
15*	504409	1	O-ring—AS 568-013
16*	501080	1	Back-up Ring—S-11248-08
17*	505040	1	C-ring
18	100236	1	Washer - Ejector
19	122705	1	Ejector - Pintail
20	111287	1	Handle Assembly (includes 21)
21*	501218	1	Screw - Soc. Hd. Cap—#10-24 X 7/8
22	111966	1	Valve - Unloading
23	112004	1	Piston (includes 24 & 25)
24*	503752	2	Back-up Ring—S-11248-337
25*	504674	1	O-ring—AS 568-337
26	111283	1	Cylinder Cap (includes 27 & 28)
27*	504498	1	O-ring—AS 568-235
28*	501162	1	Back-up Ring—S-11248-235
29	104589	1	Locator
30	111141	1	Ring - Locking
31*	500181	1	Lock Washer
32*	502489	1	Screw - But. Hd. Cap—1/4-20 X 3/8
33	104619	1	Grommet - Strain Relief
34	110940	1	Control Cord Assem. (Incl. 35)
35	110835	1	Connector Assembly
--	110849	1	Tool Hose Group (Incl. 36 thru 38)
36	110842	2	Hose Hydraulic
--	110440	1	Hyd. Coupling Assm. (Incl. 37 & 38)
37	----	1	Nipple (Male)
38	----	1	Body (Female)



For latest parts, see Fig. 3

— SEE PRODUCT UPDATE IN REAR OF MANUAL (See Assembly Notes)

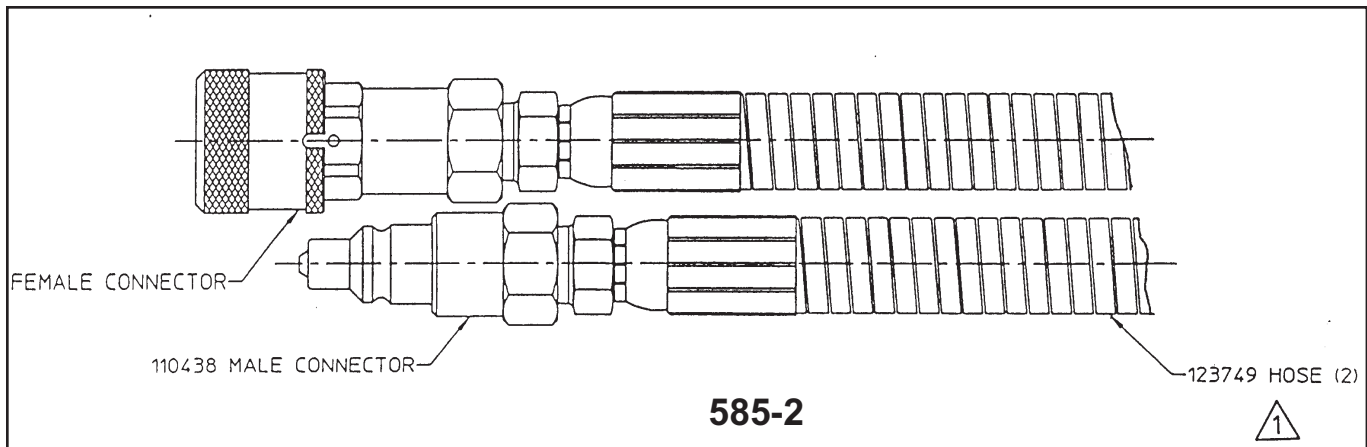
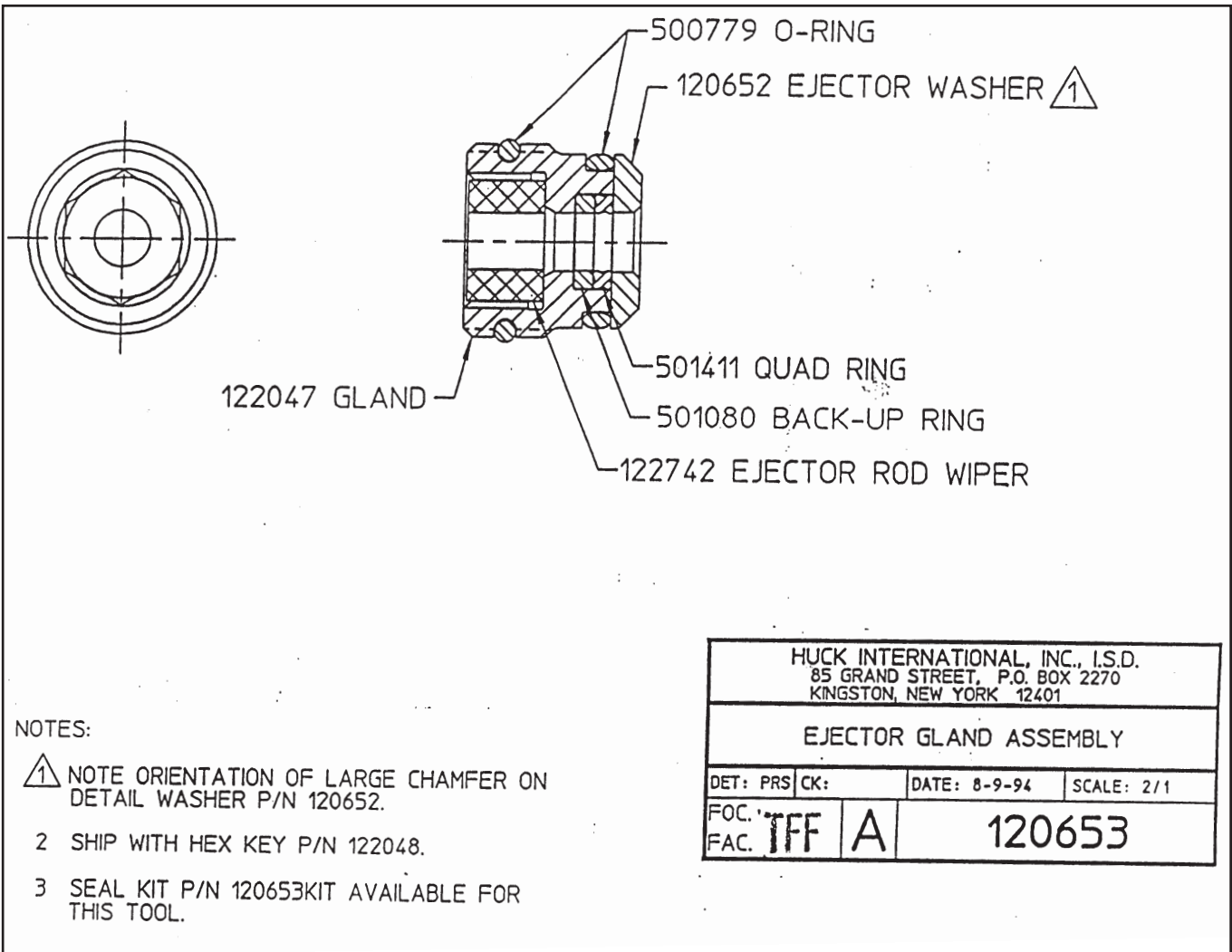
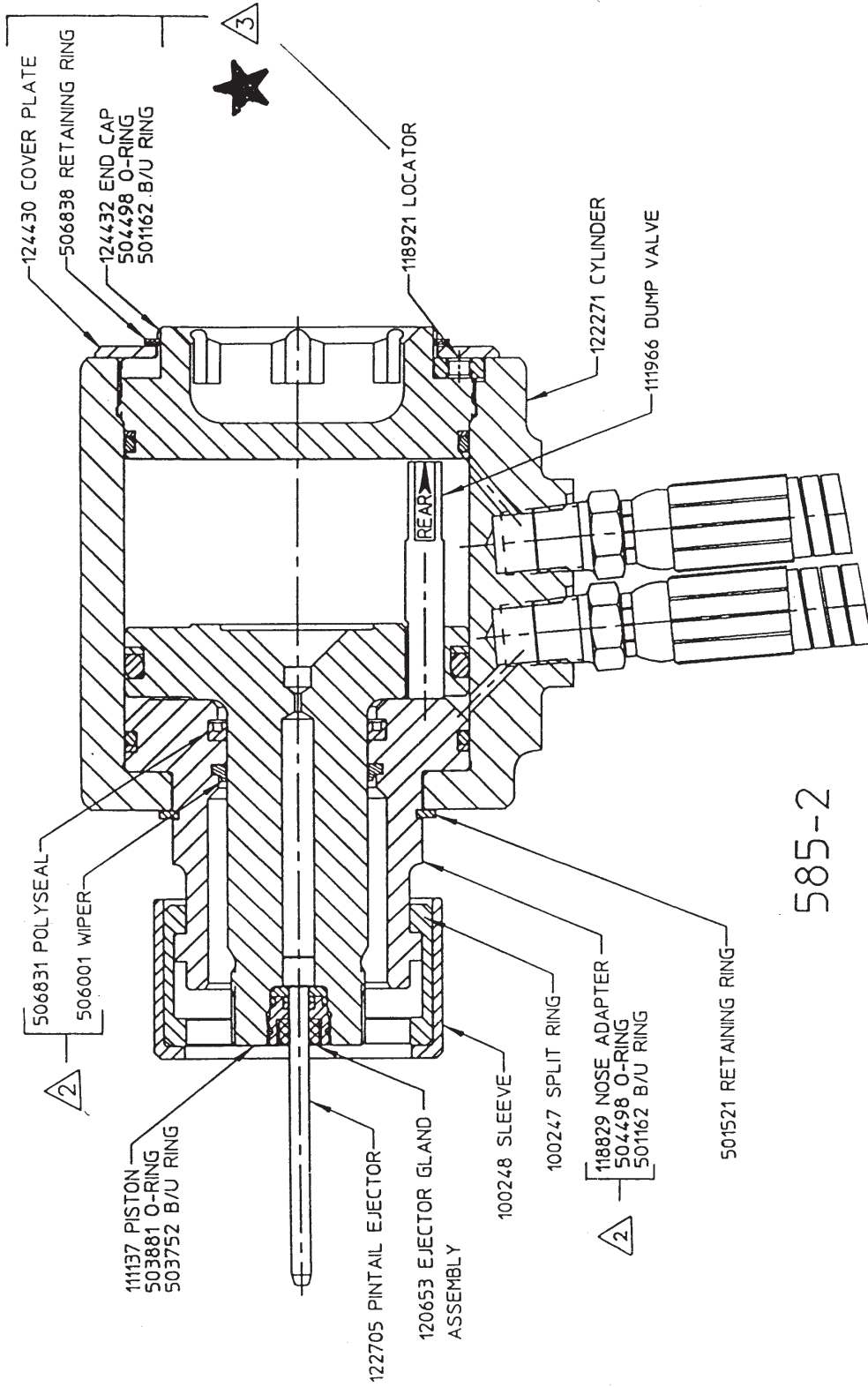



Fig. 4



585-2

PLEASE NOTE:

Assembly includes latest single component part numbers.
 To obtain entire sub-assembly when purchasing a main component, please include related parts, for example, piston; O-ring; back-up ring.

NOTES:

- 1 USE TEFLON STICK SEALANT OR EQUIVALENT ON PIPE THREADS
- 2 SERVICE KIT P/N 585KIT AVAILABLE FOR SERVICE PARTS.
- 3 SHIP WITH EJECTOR GLAND HEX KEY P/N 122048 AND END CAP HEX KEY 124434.

585-2



TROUBLESHOOTING

Always check the simplest possible cause of a malfunction first (example: a loose or disconnected trigger line). Then proceed logically and eliminate each possible cause until the defect is found. Where possible, substitute known good parts for suspected defective parts. Use the following steps as an aid in troubleshooting.

1. **Tool fails to operate when trigger is pressed.**
 - a. Inoperative POWERIG® Hydraulic Unit. See applicable instruction manual.
 - b. Loose electrical connections.
 - c. Damaged trigger assembly.
 - d. Loose or faulty hose coupling.
2. **Tool operates in reverse.**
 - a. Reversed hose connections between hydraulic unit and tool.
3. **Tool leaks hydraulic fluid.**
 - a. Defective tool O-rings or loose connections at tool.
4. **Hydraulic couplers leak fluid.**
 - a. Damaged or worn O-rings in Coupler Body Coupler
5. **Hydraulic fluid overheats.**
 - a. Unit not operating properly. See units manual.
 - b. Unit running in reverse (918; 918-5 only). See unit's manual.
6. **Tool operates erratically and fails to install fastener properly.**
 - a. Low or erratic hydraulic pressure. Air in system.
 - b. Damaged or worn Piston O-ring in tool.
 - c. Excessive wear on sliding surfaces of tool parts.
7. **Pull grooves on fastener pintail stripped during PULL stroke.**
 - a. Operator not sliding anvil completely onto fastener pintail.
 - b. Incorrect fastener grip.
 - c. Worn or damaged jaw segments.
 - d. Metal particles in jaw grooves.
 - e. Excessive sheet gap.
8. **Collar of fastener not completely swaged.**
 - a. Improper tool operation. See No. 6.
 - b. Scored anvil.
9. **Tool "hangs up" on swaged collar of fastener.**
 - a. Improper tool operation. See No. 6.
 - b. RETURN pressure too low.
 - c. Not enough collar lubricant.
 - d. Nose assembly not installed correctly.
10. **Pintail of fastener fails to break.**
 - a. Improper tool operation. See No. 6.
 - b. Pull grooves on fastener stripped. See No. 7.
 - c. PULL pressure too low.
11. **Nose will not release broken pintail.**
 - a. Nose assembly not installed correctly.
 - b. Bent or broken Pintail Ejector.

585KIT

PART NUMBER	DESCRIPTION	QTY PER ASSEMBLY
122242	EJECTOR ROD WIPER	1.000
500047	SCR SOC CAP #06-32 X .25 ZP3	1.000
500779	O-RING AS568-013 C366Y D70	2.000
501080	BACK-UP RING S-11248-08	1.000
501102	BACK-UP RING S-11248-111	1.000
501147	BACK-UP RING S-11248-220	1.000
501162	BACK-UP RING S-11248-235	2.000
501411	QUAD RING t1R—Q4009	1.000
503752	BACK-UP RING 5—11248-337	1.000
503881	O-RING AS568-337 C9250 D90	1.000
504438	O-RING AS568-111 CV747 D75	1.000
504498	O-RING AS568-235 CV747 D75	2.000
504626	O-RING AS568-220 CV25 D90	1.000
506001	WIPER MICRODOT #959-15 .	1.000
506831	POLYSEAL, MD .187-01.375SQB	1.000
8-585	REF DRAWING 585 HYD TOOL	1.000

Optional Accessory

Suspension Bracket, PR1734-585, is available. When used with a balance spring suspension system, much of the tool's weight is supported. Operator fatigue is alleviated for longer periods.



Tool & Product Update

IMPORTANT NOTICE Effective October 1, 1989

Reference - Hydraulic Installation Tool Models 504, 505,
585, UK585-2 and FE5901

The following parts have been obsoleted and superceded to Part
Number 120653 Ejector Gland Assembly.

This change has been made to reduce the leakage of hydraulic fluid
from the ejector gland area of the tools.

Part number	Description
104638	Ejector Gland Assembly
100238	Gland Ejector
100236	Washer - Ejector
505040	Seal

When customers order any of the above parts they will receive Part
Number 120653. The following service kits and Sub assemblies are
also affected, they will now contain the new gland assembly (P/N
120653)

Part Number	Description
106639	Service Kit Model 504
106640	Service Kit Model 505
110403	Service Kit Model 585
113735	Service Kit Model FE5901
106625	Piston Assembly - 504
106630	Piston Assembly - 505
111292	Piston Assembly - 585
113351	Piston Assembly - FE5901

See Reverse side for additional information



Tool & Product Update

PRODUCT IMPROVEMENT

Models 585 and 586 Improved End Cap Assemblies

End Cap Assemblies, 124433 (585) and 124431 (586) replace the existing assemblies. The new design's cover plate reduces, or eliminates, the possibility of damaging the cylinder's threads by impact - - cover plate also retains the locator disk. With wrench, 124434, cap is easily removed.

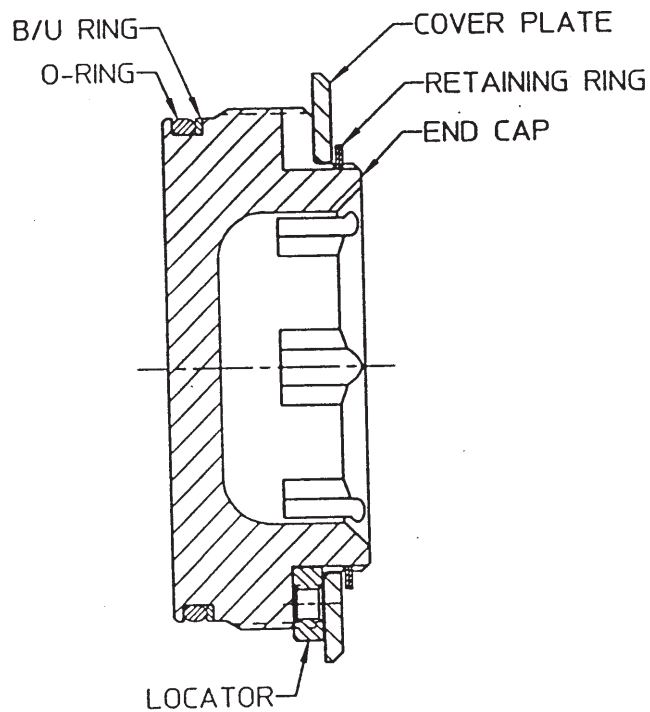

To order, please contact:

Huck International, Inc.

Installation Systems Division

800-431-3091

PATENT PENDING

*Installation Systems Division
P.O. Box 2270
Kingston, NY 12401-0250*

Rev. 8-3-95

385



LIMITED WARRANTIES

TOOLING WARRANTY:

Huck warrants that tooling and other items (excluding fasteners, and hereinafter referred as "other items") manufactured by Huck shall be free from defects in workmanship and materials for a period of ninety (90) days from the date of original purchase.

WARRANTY ON "NON STANDARD OR CUSTOM MANUFACTURED PRODUCTS":

With regard to non-standard products or custom manufactured products to customer's specifications, Huck warrants for a period of ninety (90) days from the date of purchase that such products shall meet Buyer's specifications, be free of defects in workmanship and materials. Such warranty shall not be effective with respect to non-standard or custom products manufactured using buyer-supplied molds, material, tooling and fixtures that are not in good condition or repair and suitable for their intended purpose.

THERE ARE NO WARRANTIES WHICH EXTEND BEYOND THE DESCRIPTION ON THE FACE HEREOF. HUCK MAKES NO OTHER WARRANTIES AND EXPRESSLY DISCLAIMS ANY OTHER WARRANTIES, INCLUDING IMPLIED WARRANTIES AS TO MERCHANTABILITY OR AS TO THE FITNESS OF THE TOOLING, OTHER ITEMS, NONSTANDARD OR CUSTOM MANUFACTURED PRODUCTS FOR ANY PARTICULAR PURPOSE AND HUCK SHALL NOT BE LIABLE FOR ANY LOSS OR DAMAGE, DIRECTLY OR INDIRECTLY, ARISING FROM THE USE OF SUCH TOOLING, OTHER ITEMS, NONSTANDARD OR CUSTOM MANUFACTURED PRODUCTS OR BREACH OF WARRANTY OR FOR ANY CLAIM FOR INCIDENTAL OR CONSEQUENTIAL DAMAGES.

Huck's sole liability and Buyer's exclusive remedy for any breach of warranty shall be limited, at Huck's option, to replacement or repair, at FOB Huck's plant, of Huck manufactured tooling, other items, nonstandard or custom products found to be defective in specifications, workmanship and materials not otherwise the direct or indirect cause of Buyer supplied molds, material, tooling or fixtures. Buyer shall give Huck written notice of claims for defects within the ninety (90) day warranty period for tooling, other items, nonstandard or custom products described above and Huck shall inspect products for which such claim is made.

TOOLING, PART(S) AND OTHER ITEMS NOT MANUFACTURED BY HUCK:

HUCK MAKES NO WARRANTY WITH RESPECT TO THE TOOLING, PART(S) OR OTHER ITEMS

MANUFACTURED BY THIRD PARTIES. HUCK EXPRESSLY DISCLAIMS ANY WARRANTY EXPRESSED OR IMPLIED, AS TO THE CONDITION, DESIGN, OPERATION, MERCHANTABILITY OR FITNESS FOR USE OF ANY TOOL, PART(S), OR OTHER ITEMS THEREOF NOT MANUFACTURED BY HUCK. HUCK SHALL NOT BE LIABLE FOR ANY LOSS OR DAMAGE, DIRECTLY OR INDIRECTLY, ARISING FROM THE USE OF SUCH TOOLING, PART(S) OR OTHER ITEMS OR BREACH OF WARRANTY OR FOR ANY CLAIM FOR INCIDENTAL OR CONSEQUENTIAL DAMAGES.

The only warranties made with respect to such tool, part(s) or other items thereof are those made by the manufacturer thereof and Huck agrees to cooperate with Buyer in enforcing such warranties when such action is necessary.

Huck shall not be liable for any loss or damage resulting from delays or nonfulfillment of orders owing to strikes, fires, accidents, transportation companies or for any reason or reasons beyond the control of the Huck or its suppliers.

HUCK INSTALLATION EQUIPMENT:

Huck International, Inc. reserves the right to make changes in specifications and design and to discontinue models without notice.

Huck Installation Equipment should be serviced by trained service technicians only.

Always give the Serial Number of the equipment when corresponding or ordering service parts.

Complete repair facilities are maintained by Huck International, Inc. Please contact one of the offices listed below.

Eastern

One Corporate Drive Kingston, New York 12401-0250
Telephone (845) 331-7300 FAX (845) 334-7333

Outside USA and Canada

Contact your nearest Huck International Office, see back cover.

In addition to the above repair facilities, there are Authorized Tool Service Centers (ATSC's) located throughout the United States. These service centers offer repair services, spare parts, Service Parts Kits, Service Tools Kits and Nose Assemblies. Please contact your Huck Representative or the nearest Huck office listed on the back cover for the ATSC in your area.

Alcoa Fastening Systems



One Great ConnectionSM

A Global Organization

Alcoa Fastening Systems (AFS) maintains company offices throughout the United States and Canada, with subsidiary offices in many other countries. Authorized AFS distributors are also located in many of the world's

Industrial and Aerospace centers, where they provide a ready source of AFS fasteners, installation tools, tool parts, and application assistance.

Alcoa Fastening Systems world-wide locations:

Americas

Alcoa Fastening Systems
Aerospace Products
Tucson Operations
3724 East Columbia
Tucson, AZ 85714
800-234-4825
520-747-9898
FAX: 520-748-2142

Alcoa Fastening Systems
Aerospace Products
Carson Operations
PO Box 5268
900 Watson Center Rd.
Carson, CA 90749
800-421-1459
310-830-8200
FAX: 310-830-1436

Alcoa Fastening Systems
Industrial Products
Waco Operations
PO Box 8117
8001 Imperial Drive
Waco, TX 76714-8117
800-388-4825
254-776-2000
FAX: 254-751-5259

Alcoa Fastening Systems
Industrial Products
Kingston Operations
1 Corporate Drive
Kingston, NY 12401
800-278-4825
845-331-7300
FAX: 845-334-7333

Alcoa Fastening Systems
Industrial Products
Latin America Operations
Avenida Parque Lira. 79-402
Tacubaya Mexico, D.F.
C.P. 11850
FAX: 525-515-1776
TELEX: 1173530 LUKSME

Far East

Alcoa Fastening Systems
Industrial Products
Australia Operations
14 Viewtech Place
Rowville, Victoria
Australia 3178
03-764-5500
Toll Free: 008-335-030
FAX: 03-764-5510

Europe

Alcoa Fastening Systems
Industrial Products
United Kingdom Operations
Unit C, Stafford Park 7
Telford, Shropshire
England TF3 3BQ
01952-290011
FAX: 0952-290459

Alcoa Fastening Systems
Aerospace Products
France Operations
Clos D'Asseville
BP4
95450 Us Par Vigny
France
33-1-30-27-9500
FAX: 33-1-34-66-0600



For The Long Haul, The Future of Fastening Technology, The Future of Assembly Technology, The Future of Tooling Technology, and Tools of Productivity are service marks of Huck International. Huck provides technical assistance regarding the use and application of Huck fasteners and tooling.

NOTICE: The information contained in this publication is only for general guidance with regard to properties of the products shown and/or the

means for selecting such products, and is not intended to create any warranty, express, implied, or statutory; all warranties are contained only in Huck's written quotations, acknowledgements, and/or purchase orders. It is recommended that the user secure specific, up-to-date data and information regarding each application and/or use of such products.

HWB898 1003-5M



For the Long Haul™