

Alcoa
Fastening
Systems



HUCK MODEL 964 *POWERIG*®

SPX MODEL PE104-HUCK



Makers of Huck®, Marson®, Recoil®
Brand Fasteners, Tools & Accessories

05-10-2007
HK1053



THIS PAGE INTENTIONALLY BLANK

CONTENTS

| | |
|---|---|
| SETUP AND OPERATION | 4 |
| ELECTRIC MOTOR WARNING | 4 |
| HYDRAULIC SETUP | 4 |
| FILLING THE BLADDER | 4 |
| TANDEM CENTER 4-WAY CONTROL VALVE | 5 |
| PRESSURE SWITCH | 6 |
| ADJUSTING THE PRESSURE SWITCH SETTING | 6 |
| PREVENTIVE MAINTENANCE | 6 |

PLEASE USE THE FOLLOWING INSTRUCTIONS FOR SET-UP AND OPERATION

(REPLACES SET-UP AND OPERATION IN SPX MANUAL)

Electric Motor



WARNING To help avoid possible personal injury,

- Any electrical work must be done by a qualified electrician.
- Disconnect the power supply before removing the motor casing cover or performing repairs or maintenance.

Hydraulic Set-up (Refer to Fig 1 - 4)

1. Clean the areas around the oil ports of the pump.
2. Inspect the threads and fittings for signs of wear or damage and replace as needed. Clean all hose ends and couplers.
3. Seal all pipe connections with a high quality pipe thread sealant. Use Teflon stick to seal hydraulic connections.

Filling the Bladder (Only As Required)

1. Thoroughly clean the area around the filler cap with a clean cloth to prevent contamination of the oil by foreign particles.
2. Make sure the valve control lever is in the neutral position.
3. Remove the filler cap and insert a clean funnel with filter. Bladder must be filled to the top of filler. All air must be out of bladder.
4. Replace filler cap. **IMPORTANT: Tighten filler cap 1/2 - 1 turn after o-ring contacts sealing surface. Overtightening can cause pump damage.**

Huck Model 964POWERIG® SPX MODEL PE104-HUCK

(CONTINUED)

PLEASE USE THE FOLLOWING INSTRUCTIONS FOR SET-UP AND OPERATION
(REPLACES SET-UP AND OPERATION IN SPX MANUAL)

Tandem Center 4-Way Control Valve used with Huck Tooling

1. Turn the valve control lever to the NEUTRAL position. (Fig. 1)
2. Start the pump by pressing the motor control ON/OFF switch. (Fig.1)
3. Turn lever to Pull Side, Huck tool will pull back installing the fastener. (Cutting the collar if cutter nose is used) (Fig. 1 & 4)
4. Turn lever to Return Side, Huck tool will return to full forward position pushing off collar (releasing cutter if used). (Fig. 1 & 2)

NOTE: The cylinder momentarily loses pressure during the transition between valve positions.

5. Turn the valve control lever to the NEUTRAL position. Shut pump off by pressing the motor control ON/OFF switch. (Fig. 1)

NOTE: Refer to SPX Manual for all other information

Model 964 POWERIG® SPX MODEL PE104-HUCK

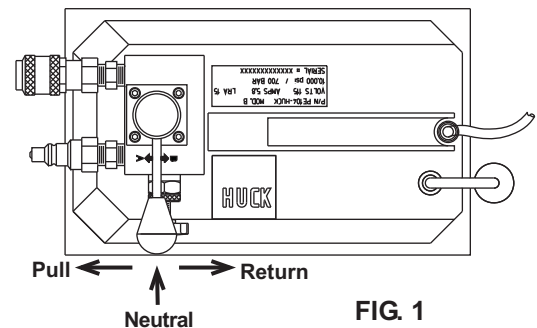

FIG. 1

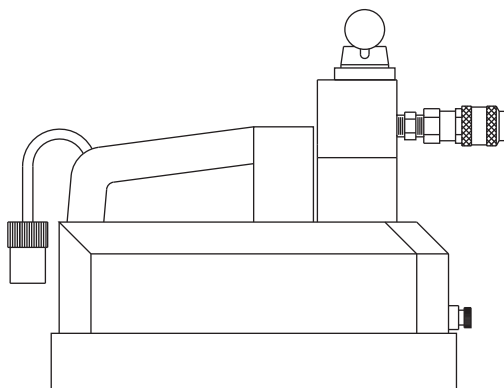

FIG. 2

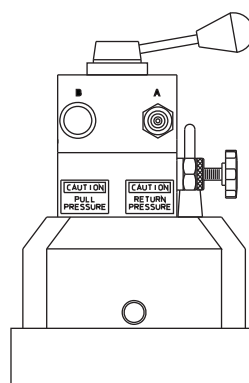

FIG. 3

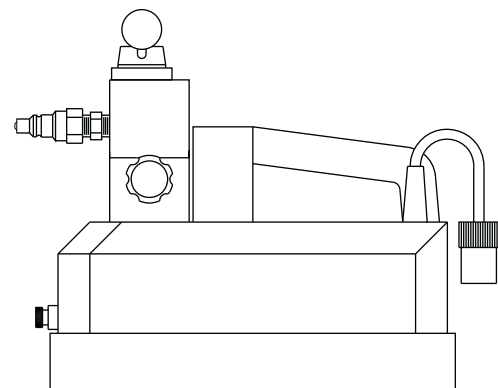

FIG. 4

Pressure Switch

A pressure switch can be adjusted to stop the pump motor at a desired pressure setting and restart the motor when the pressure falls below that setting.

It is recommended that a pressure switch be used with a pressure regulating valve to insure accuracy when setting a maximum PSI level. A pressure switch alone will break the motor's energy supply at a selected setting, but the hydraulic pump will continue building pressure as it slows to a stop. The pressure regulating valve is adjusted at a setting slightly above the pressure switch setting to compensate by releasing the pressure developed by the hydraulic pump as it "coasts" to a stop. As a result, the pressure limit requirement can be held to approximately 300 PSI.

Adjusting the Pressure Switch Setting

1. Loosen the locknut on the pressure switch. Slowly turn the pressure switch adjusting screw in a counterclockwise (CCW) direction, decreasing the pressure switch setting until the pump motor shuts off. Tighten the locknut to lock the adjusting screw.
2. Release the hydraulic pressure. Run the pump to check the pressure setting and automatic shutoff of the motor. It may be necessary to make a second fine adjustment.

PREVENTIVE MAINTENANCE

Electric Motor

 **WARNING** To help avoid possible personal injury,

- **Disconnect the pump from the power supply before performing maintenance or repair procedures.**
- **Repairs and maintenance should be performed in a dust-free area by a qualified technician.**

Bleeding Air from the System

Air can accumulate in the hydraulic system. This air causes the cylinder to respond in an unstable or slow manner. To remove the air:

1. Position hydraulic cylinder(s) on their sides with the couplers located upward and at a lower level than the pump.
2. Remove any load from the cylinder(s), and cycle the hydraulic system through several cycles (fully extend and retract the cylinders).
3. The bladder must be vented and refilled (see "Filling the Bladder" on page 4).

Hydraulic Fluid Level

1. Check the oil level in the bladder after each 10 hours of use. With all cylinders retracted and the pump in the upright (or vertical) position, the oil level should be at the top of the filler hole.
2. When adding oil, use Power Team approved, high-grade hydraulic oil (215 SSU @ 100° F). Retract the cylinders and disconnect the power supply. Clean the area around the filter plug, remove the plug, and insert a clean funnel with filter.
3. The frequency of oil changes will depend upon the general working conditions, severity of use, and overall cleanliness and care given the pump. Three hundred hours of use under general shop conditions is considered a standard change interval. Drain, flush, and refill the bladder with Power Team approved, high-grade hydraulic oil (215 SSU @ 100° F).

Maintenance and Cleaning

1. Keep the pump's outer surface as free from dirt as possible.
2. Seal all unused couplers with thread protectors.
3. Keep all hose connections free of dirt and grime.
4. Equipment connected to the pump must be kept clean.
5. Use only Power Team approved, high-grade hydraulic oil in this pump. Change as recommended (approx. every 300 hours).